

# Polaris V2 Fato Heliport

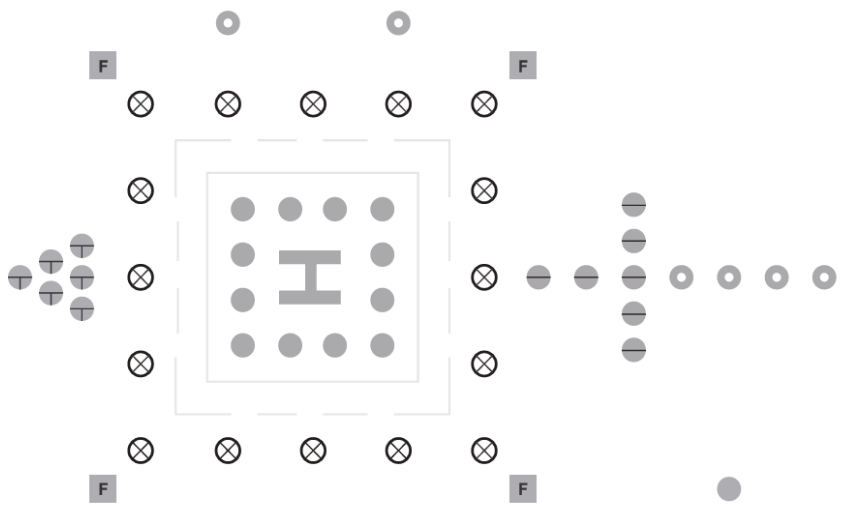

|                                       |  |                                      |           |                   |            |             |           |                          |           |
|---------------------------------------|--|--------------------------------------|-----------|-------------------|------------|-------------|-----------|--------------------------|-----------|
| <p><b>Compliance to standards</b></p> | <p><b>ICAO:</b><br/>International Civil Aviation Organization, Aerodromes, Annex 14, Vol. 2 fig. 5.12 illustration 5.</p> <p><b>IEC TS 61827:</b><br/>Electrical installations for lighting and beaconing of aerodromes. Characteristics of inset and elevated luminaires used on aerodromes and heliports.</p>  |                                      |           |                   |            |             |           |                          |           |
| <p><b>Application</b></p>             | <p>Aiming point and FATO lights (Final Approach and Take Off Area)</p>  <p>The diagram illustrates the layout of aiming point and FATO lights. It features a central 'I' shaped aiming point light within a square FATO area. Surrounding this are various light configurations: floodlights (labeled 'F'), approach lights (represented by circles with horizontal bars), taxiway lights (circles), TLOF lights (solid circles), and a beacon light (solid circle). A legend at the bottom identifies each symbol: Aiming Point Lights (circle with horizontal bars), Taxiway Lights (circle), FATO Lights (circle with 'X'), TLOF Lights (solid circle), Floodlights (square with 'F'), Approach Lights (circle with horizontal bars), and Beacon Light (solid circle).</p> |                                      |           |                   |            |             |           |                          |           |
| <p><b>Features</b></p>                | <p>Designed and built with simplicity and ease of maintenance in mind.<br/>High power LED technology<br/>Lightweight, low-energy and environment friendly lighting fitting.<br/>Extensive use of aluminum alloys reduces fitting weight and eases handling in the field.</p>   |                                      |           |                   |            |             |           |                          |           |
| <p><b>Product Code</b></p>            | <p><b>AL - 175 - 01 - WH</b></p> <table border="0"> <tr> <td>Series Indicator (Airfield Lighting)</td> <td><b>AL</b></td> </tr> <tr> <td>Product Indicator</td> <td><b>175</b></td> </tr> <tr> <td>LEDs Number</td> <td><b>01</b></td> </tr> <tr> <td>LEDs Light Color (White)</td> <td><b>WH</b></td> </tr> </table>  | Series Indicator (Airfield Lighting) | <b>AL</b> | Product Indicator | <b>175</b> | LEDs Number | <b>01</b> | LEDs Light Color (White) | <b>WH</b> |
| Series Indicator (Airfield Lighting)  | <b>AL</b>  |                                      |           |                   |            |             |           |                          |           |
| Product Indicator                     | <b>175</b>   |                                      |           |                   |            |             |           |                          |           |
| LEDs Number                           | <b>01</b>  |                                      |           |                   |            |             |           |                          |           |
| LEDs Light Color (White)              | <b>WH</b>  |                                      |           |                   |            |             |           |                          |           |

**Control options**

- Local with Polaris buttons

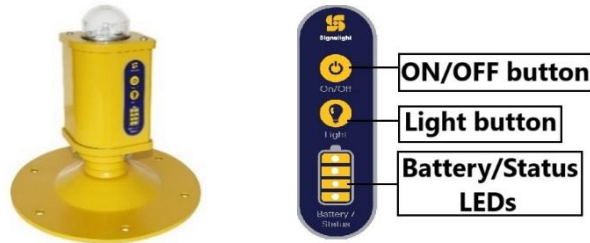

- Via remote controller using LORA technology in 868 MHz for Europe, 915 MHz for US, optional 433 MHz



- Via POLARIS computer interface using a POLARIS base station.

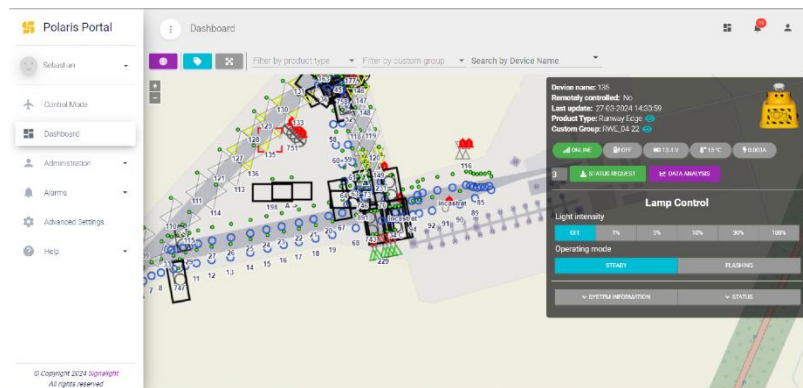





**Description**

**Housing** - powder coated aluminum RAL 1004 (aviation yellow) ●  
**Disperser** - glass  
**Cable gland** - nickel plated brass  
**Fasteners** - stainless steel  
**Casing** - powder coated aluminum RAL 1004 (aviation yellow)

**Environment**

**Temperature range:** - 55° to +55°  
**Degree of protection:** IP67  
**Humidity:** 0-100%

|  |   |  |
|--|---|--|
| <p><b>Mounting</b></p>                   | <p>On a base plate or tripod</p>   | <p>Including Solar panel stand</p>  |
| <p><b>Electrical Characteristics</b></p> | <p><b>Power consumption:</b> maximum 4 W powered at 100% brightness</p> <p><b>Power supply:</b> Power supply is provided by 1 rechargeable NiMh battery 12 V – 2,7 Ah</p> <p><b>Solar panel:</b> 10 W</p> <p><b>Autonomy under ideal conditions</b><br/>(new battery, fully charged at 100%, external temperature of 20° Celsius)</p> <p><b>Brightness level:</b></p> <ul style="list-style-type: none"> <li>100% - 8 hrs</li> <li>30% - 26.6 hrs</li> <li>10% - 80 hrs</li> <li>3% - 265 hrs</li> <li>1% - 800 hrs</li> </ul>  |  |
| <p><b>Charging</b></p>                   | <p>Charging can be done using individual chargers for 1/6/10 lamps, racks designed for multiple lamps, or a solar panel.</p> <div style="display: flex; justify-content: space-around;"> <div data-bbox="566 1512 885 1758"> <p>Individual charger 1/6/10</p>  <p>Charging time: 15 hours</p> </div> <div data-bbox="1061 1512 1380 1758"> <p>Rack</p>  <p>Charging time: 15 hours</p> </div> </div> <div style="text-align: center; margin-top: 20px;"> <p>Solar panel</p>  <p>Charging time: Depending on weather conditions</p> </div> |  |

## Local/manual Control

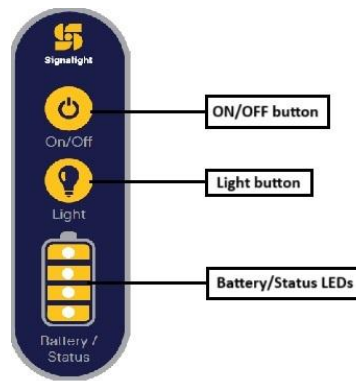

After mechanical installation is done, push the ON/OFF button. This will connect the battery and the POLARIS unit will be powered. As long as the unit is powered the yellow LED from the SIGNALIGHT LOGO will flash every 5 seconds. In this moment the lights are in STANDBY mode.

To start the MAIN LEDs push the "Light button". At the first push the battery level will be indicated with the signal LEDs:

- First LED ON means the battery is between 0 to 25 % charged
- First two LEDs ON means the battery is between 25 to 50 % charged
- Three LEDs ON means the battery is between 50 to 75 % charged
- All four LEDs ON means the battery is between 75 to 100 % charged

The battery level indication expires in about 10 seconds and the status LEDs will turn OFF.

If the "Light button" will be pushed again MAIN LEDs will turn ON at 1%, after another push will go to 3%, then to 10%, 30% and 100%. After another push the light will turn OFF and the POLARIS unit will go in STANDBY.

### **Disconnecting the battery**

If the "Light button" is pressed for longer than 3 seconds the battery will be disconnected. This operation is recommended if the lamps are going to be stored for a longer period of time or during transport. In this stage the consumption is zero. When the Polaris is disconnected, the main LEDs will flash for 3 times.

### **Photocell option function**

Optional, the POLARIS lights can work on base of photocell just during the night. In this case the cycle made with the push button is: - battery status, 1 %, 3 %, 10%, 30%, 100%, photocell mode, standby When the photocell mode is selected, the main LEDs will flash for 5 times.

Control of the lamps can be done locally using the buttons on the control panel of the lamps or via the control application.

**LOCAL CONTROL**

All lamps have a control panel that includes two buttons and four signaling LEDs. Additionally, there is an orange LED in the middle of the LOGO SIGNALIGHT symbol.



After installation, pressing the On/Off button closes the power circuit between the battery and the lamp. After pressing the button, the first LED of the battery status will light up:



At this moment, the lamp requests access to the system. After a few seconds, the lamp receives access to the system, at which point the third LED will light up:



**Radio control**

From this moment on, the lamp can also be controlled via the application. Locally, the "Light button" can be pressed. Upon the first press, the battery level can be viewed:

|                            |                           |                           |                          |
|----------------------------|---------------------------|---------------------------|--------------------------|
| Battery Charged<br>75-100% | Battery Charged<br>50-75% | Battery Charged<br>25-50% | Battery Charged<br>0-25% |
|----------------------------|---------------------------|---------------------------|--------------------------|



On the second press, the lamp turns on at 1%. With another press, it turns on at 3%, then at 10%, then at 30%, and finally at 100%. If pressed again, the lamp turns off.

If the "Light button" is held down for more than 5 seconds, the lamp will flash three times and then turn off (disconnecting the power from the battery).

To restart it, the On/Off button must be pressed.

Optional the POLARIS lights can be radio controlled.

Radio control is made using LORA technology in 868 Mhz for Europe or 915 Mhz for US, optional 433 Mhz.

The lights can be controlled one way using a handled remote control.



One way communications means all the lights can be started at 1%, 3%, 10%, 30% or 100% or switched OFF.

Optionally, the lamps can be controlled in groups, pre-set at the factory through a customized remote control

Another option is to control the lights using a base station, in this case the communication is bidirectional via POLARIS application.

The distance covered can be up to 10 km in line of sight.

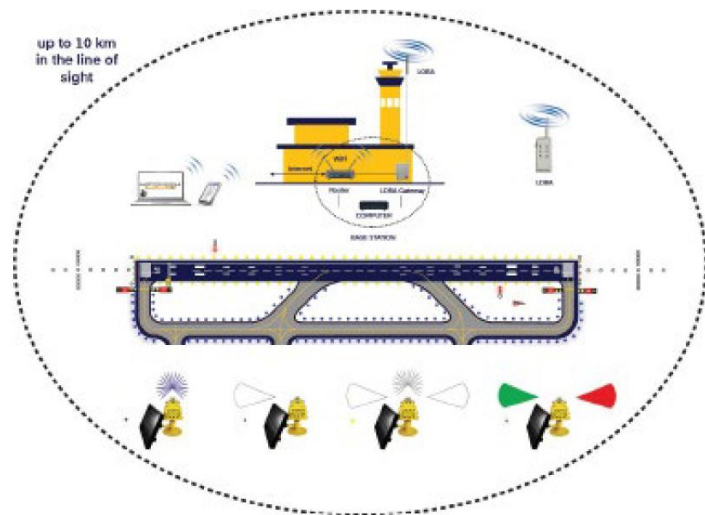

From the POLARIS application the control is more complex. The lights can be controlled individual, in groups, on scenarios and the user can see all the parameters of the lights.

ARCAL – Pilot activation



This option allows pilots to activate the lights using the communication system. If you click three times on the microphone, the lamps will work at 10%, after five clicks, the lamps will work at 30% of intensity, and after 7 clicks, the lamps will work at 100%.



**Mechanical  
Characteristics**

**Dimensions:**

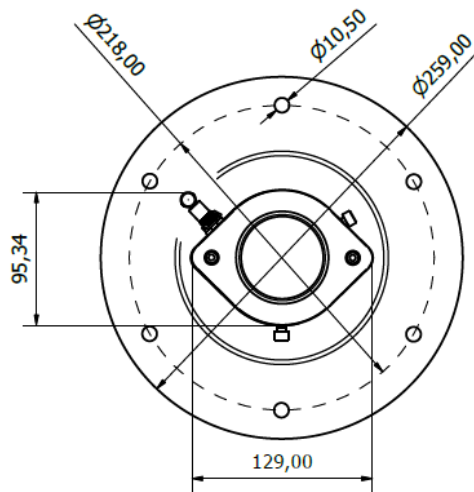
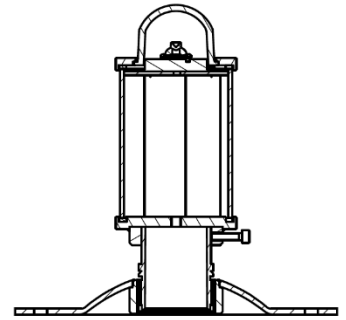
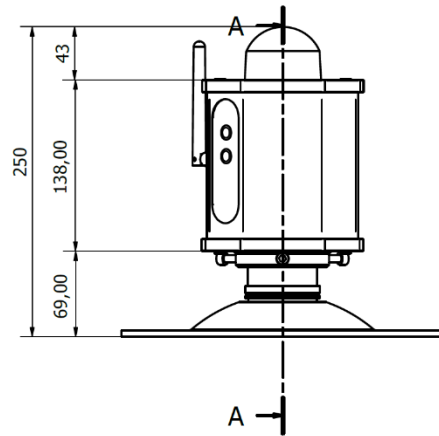

**Photometric  
Characteristics**

**Intensity level:** 1%, 3%, 10%, 30%, 100%  
**Horizontal output:** 360°  
**Light color:** White light

| Vertical elevation angle        | 0°    | 3°    | 10°   | 20°   | 25°  | 30°  |
|---------------------------------|-------|-------|-------|-------|------|------|
| Required minimum intensity [cd] | 10    | 100   | 100   | 100   | 50   | 10   |
| Measured minimum intensity [cd] | 194.3 | 241.2 | 259.7 | 118.1 | 74.1 | 57.2 |

The light color emitted by the light fixture is white, with the trichromatic coordinates:

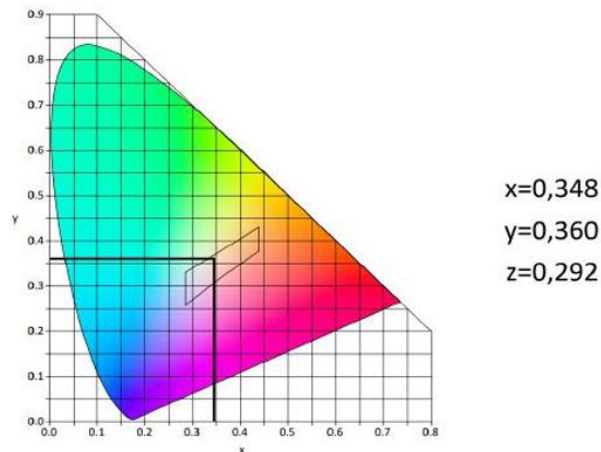

The measured trichromatic coordinates correspond to color range requirements in:

**ICAO Annex 14 – Aerodromes Vol.1, fig, A1-1b.  
 Colors for aeronautical ground lights (solid state lighting)**

**Spare Parts**

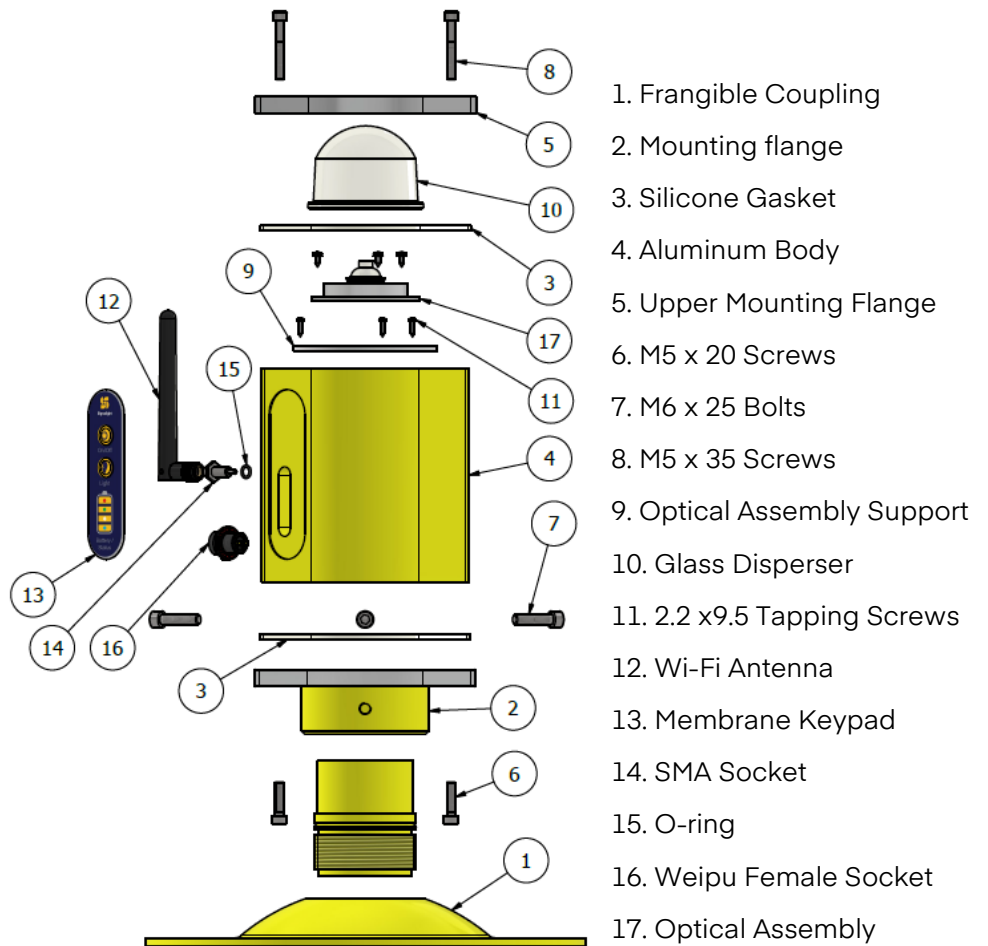

- 1. Frangible Coupling
- 2. Mounting flange
- 3. Silicone Gasket
- 4. Aluminum Body
- 5. Upper Mounting Flange
- 6. M5 x 20 Screws
- 7. M6 x 25 Bolts
- 8. M5 x 35 Screws
- 9. Optical Assembly Support
- 10. Glass Disperser
- 11. 2.2 x9.5 Tapping Screws
- 12. Wi-Fi Antenna
- 13. Membrane Keypad
- 14. SMA Socket
- 15. O-ring
- 16. Weipu Female Socket
- 17. Optical Assembly



**Signalight**

**+40 254 515 465**  
**office@signalight.com**

36 Lunca Street, Petrosani,  
Hunedoara County, Romania

**[www.signalight.com](http://www.signalight.com)**