

Clinometer

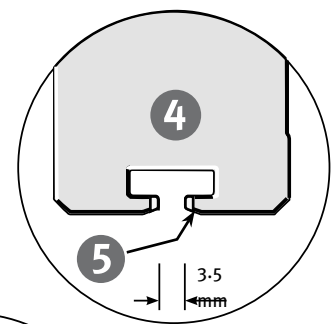

<p>Product Code</p>	<p>AL - 115 - AX</p> <p>Series Indicator (Airfield Lighting) AL Product Indicator 115 Description of product type (Accessory) AX</p>
<p>Description</p>	<p>Accuracy 0° / 90° / 180° / 270° ± 0,05° Batteries 2 x 1,5 V alkaline, Mignon, AA, LR6, MN1500 Battery life >150 hours Housing material Aluminium / PC-ABS</p>
<p>Environment</p>	<p>Operating temperature range 10 °C to 50 °C / 14 °F to 122 °F Storage temperature range -20 °C to 65 °C / -4 °F to 149 °F Degree of protection IP65</p>
<p>Inserting batteries battery replacement</p>	<div data-bbox="549 1258 1471 1576"> </div> <p>Unscrew battery compartment lid, insert new batteries into battery compartment according to symbol. Suitable rechargeable batteries can also be used.</p> <div data-bbox="549 1756 705 1823"> </div> <p>LCD indicator: Battery low – insert new batteries</p> <div data-bbox="526 1868 711 2033"> </div> <p>Dispose of used batteries at suitable collection points – not with household waste. Do not leave in unit!</p> <p>If you do not intend to use the unit for an extended period, remove the batteries.</p>

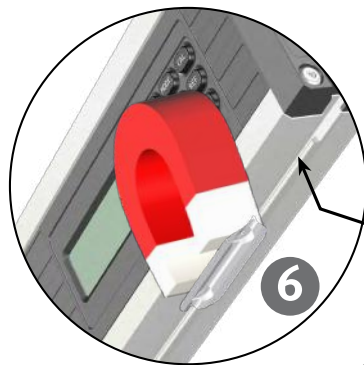
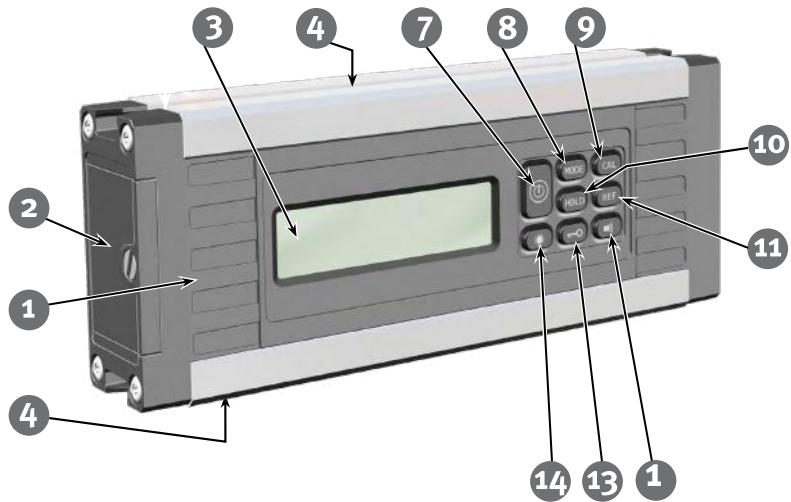

Components of the unit

- 1 - TECH 500 DP (dust-proof and waterproof in accordance with IP 65)
- 2 - Battery compartment lid
- 3 - Display
- 4 - T-groove profile for securing with M4 groove stones, e.g. Bosch Rexroth® or square nut in accordance with DIN 557
- 5 - V-shape for aligning on round surfaces
- 6 - Rare-earth magnet
- 7 - Buttons ON/OFF
- 8 - Units of measurement: °, %, mm/m, in/ft
- 9 - Calibration and sensor adjustment
- 10 - HOLD – locking measurements
- 11 - Reference – freely selectable zero position
- 12 - Acoustic guidance
- 13 - Key lock
- 14 - Display lighting

Display elements

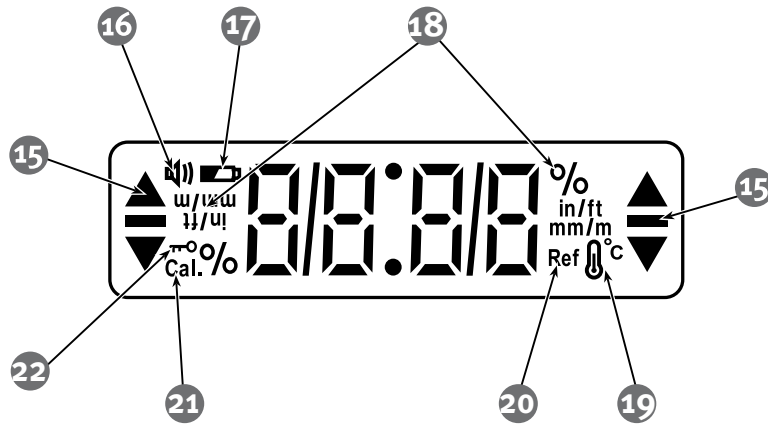

- 15 - Elements for visual guidance
- 16 - Acoustic guidance: activated
- 17 - See chapter 5.1
- 18 - Units of measurement: °, %, mm/m, in/ft
- 19 - See chapter 7.4
- 20 - Reference: activated
- 21 - See chapter 7.4
- 22 - Key lock: activated

Switching the until on

The sequence of screens during the power-on test is as follows:

- Test screen showing all display elements.
- Software Version: S 1.00
- Auto OFF: 1/8h
- Angle measurement: 0.00° with an acoustic signal icon and "OK" checkmark.

After switching on with the "ON/OFF" button, an automatic test is carried out.

All the display's segments are shown.

After the end of the test, the version number S x.xx of the software is briefly displayed and the automatic switch-off time (Auto OFF) is shown.

An acoustic signal indicates that the unit is ready for operation. The display shows the angle measured in the set unit of measurement.

Visual guidance

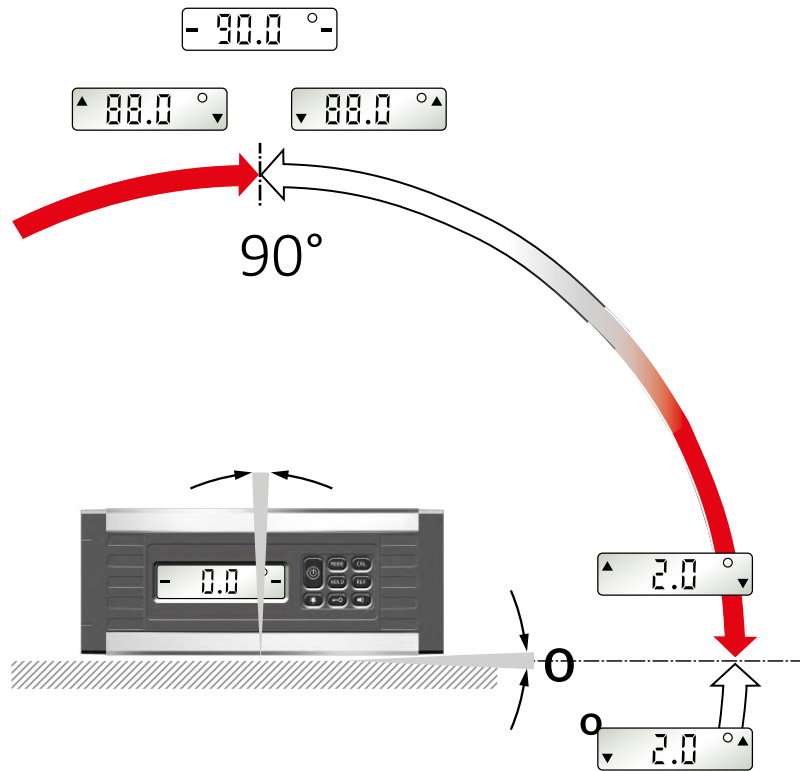

In the range of $\pm 15^\circ$ to the horizontal (0°) or to the vertical (90°), arrows show which way to turn the digital protractor to reach 0° or 90° .

The 2 "centre display" bars indicate the precise position at which 0° or 90° is reached.

Acoustic guidance

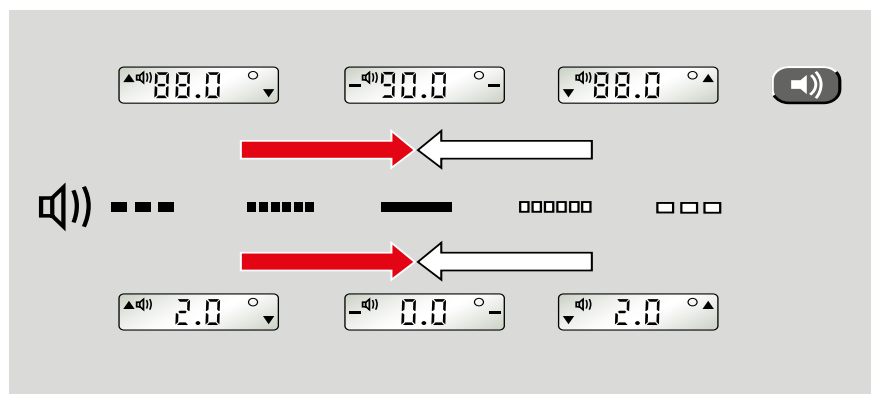

The acoustic guidance is activated/deactivated using the "Loudspeaker" button. The tone sequence speeds up as the 0° or 90° position is approached in a range of $\pm 2^\circ$. A change in the pitch indicates that these positions have been exceeded.

A continuous tone confirms the precise point at which 0° or 90° is reached.

Automatic display inversion



The display is inverted for overhead measurements so that they are always easy to read.

Setting the MODE unit of measurement

	%	
	mm/m	

Mounting

The unit of measurement is set by pressing the "MODE" button several times.

- ° Fine: Display in 0.01° steps
- ° Rough: Display in 0.1° steps
- %: Display in 0.1 % steps
- mm/m: Display in 1 mm/m steps
- in/ft decimal: Display in 0.01 in/ft steps
- in/ft fraction: Display in 1/8 in/ft steps

The set unit of measurement is retained after the unit is switched off.

Locking the measurement with HOLD



The current measurement can be locked by pressing the "HOLD" button. The visual guidance indicator flashes. The measurement is displayed continuously. The locked measurement is deleted by pressing the "HOLD" button again or switching the unit off.

Freely selectable zero position REF

The "REF" button can be used to select any set angle as 0° reference. The angle details now displayed relate to this reference angle. The displayed value flashes with this setting.

A:

The reference angle value is displayed for 2 seconds by briefly pressing the "REF" button.

B:

The reference angle is deleted by:
 Pressing and holding (→ 3 sec) the "REF" button. The activated button lock must be released before deleting the angle.
 Switching off.
 The automatic switch-off function.
 The zero position then refers back to the original setting.



The alignment selected for the digital protractor must not be changed during the reference function, as this could lead to a display error.

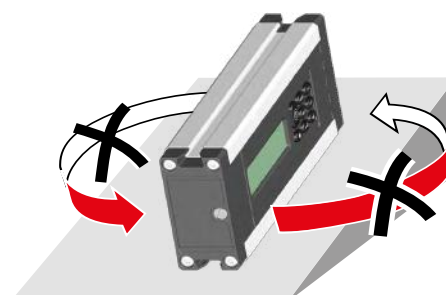

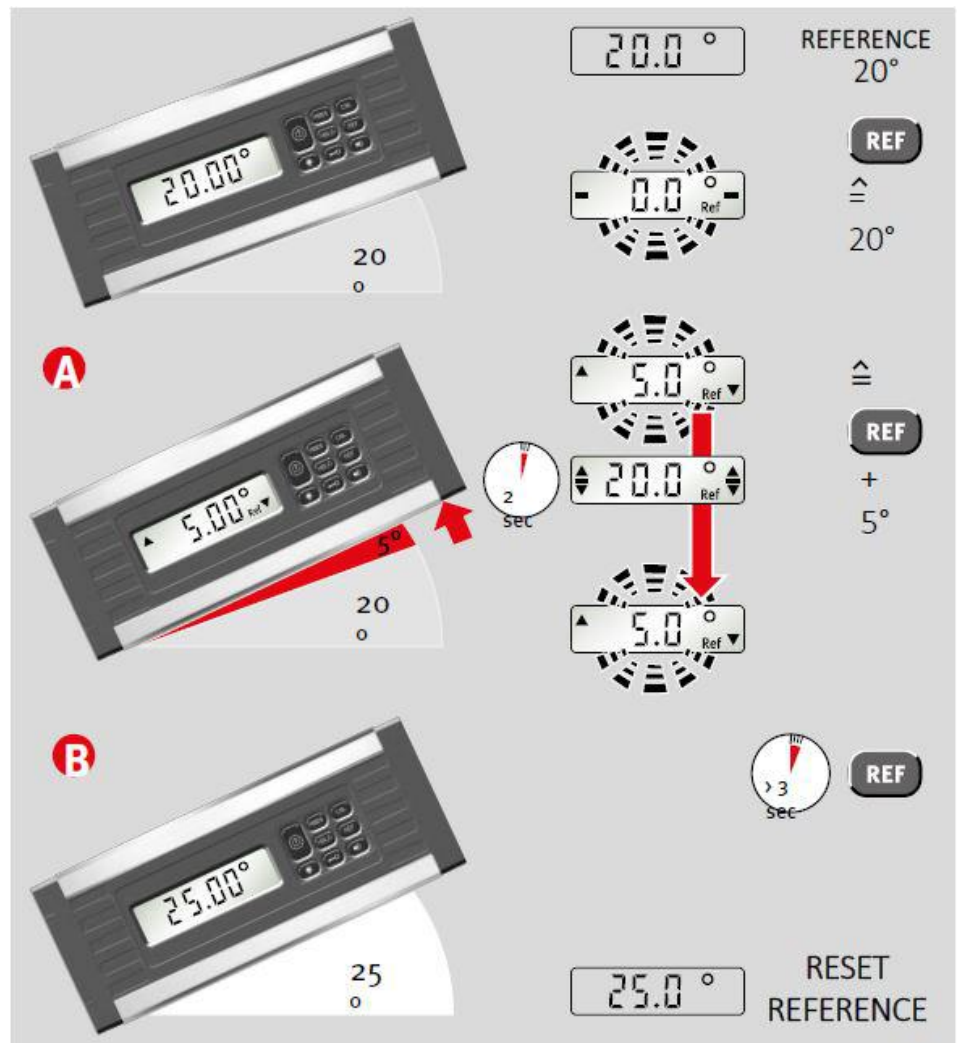

Lighting

Briefly pressing the "Lighting" button switches the display lighting on for approx. 60 seconds.
 Pressing and holding (→ 5 sec) the "Lighting" button makes the lighting darker and switches it on permanently.
 The lighting is switched off by pressing the "Lighting" button again, or by switching off the unit.

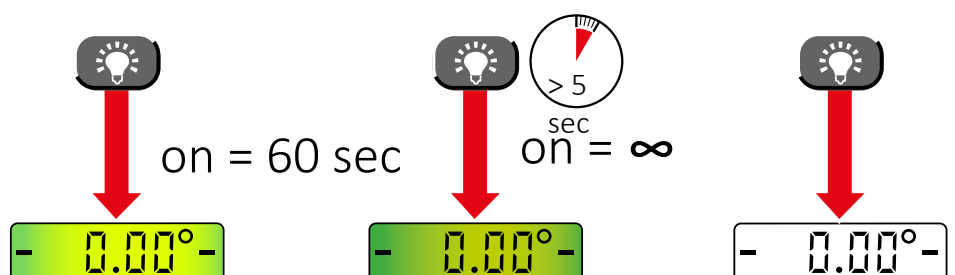

Key lock

Function: Key lock to prevent inadvertent activation.
 Display after activation: key symbol.

The lock is activated for the following buttons: "MODE, CAL, HOLD, REF".

The key lock remains active after switching the unit off and back on again!
 Pressing and holding (> 3 sec) the "Key" button disables the key lock.



**Automatic
 switch-off
 time:
 Auto OFF**

Pressing the "Lighting" and "Acoustic guidance" buttons at the same time allows the automatic switch-off time to be changed from 1/8 of an hour (approx. 7.5 minutes) to 2 hours. The set switch-off time is retained after the unit is switched off and is displayed briefly when it is switched on again.

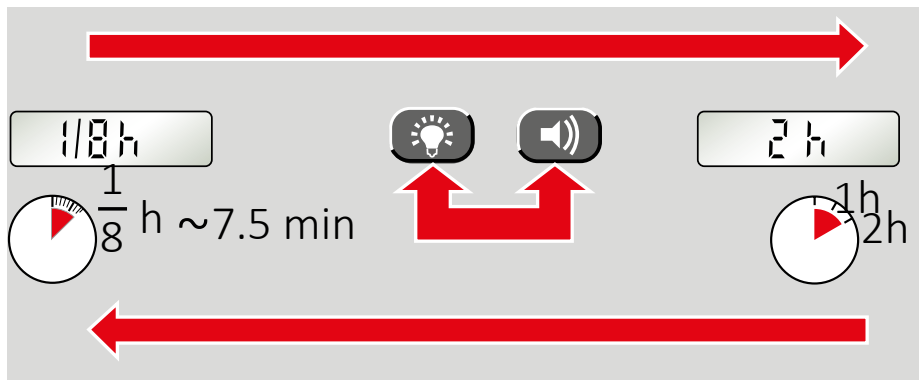



To prevent incorrect measurements, the accuracy must be checked at regular intervals, e.g. before you start work, or after hard knocks or major changes in temperature.

Step 1:

Place the device with the lower measuring sole on as horizontal a surface as possible (e.g. table) with the display side facing the user. Determine the measurement.

Step 2:

Turn the unit by 180° in the same position.

Step 3:

The rear of the unit is now facing the user. Compare the new measurement with the measurement determined in step 1. In the case of deviations > 0.05°, the unit must be calibrated again (-> Calibration).

Accuracy check

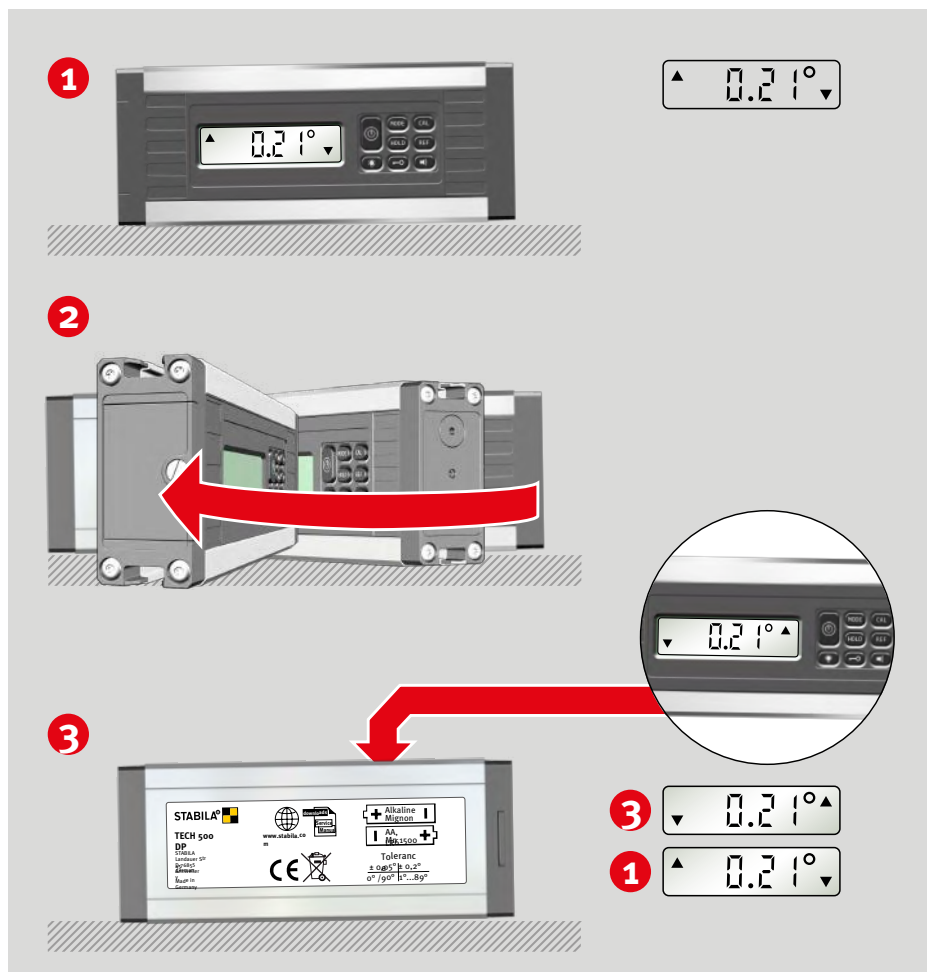

Calibration

The measuring sole calibration is activated with the "CAL" button.

-CAL- display:

Step 1:

Place the device with the lower measuring sole on as horizontal a surface as possible (e.g. table) with the display side facing the user. The first calibration is started by pressing the "CAL" button. CAL flashes in the display.

-CAL2- display: Calibration step 1 successfully completed.

Step 2:

Turn the unit by 180° in the same position.

Step 3:

The rear of the unit is now facing the user. The second calibration is started by pressing the "CAL" button. CAL flashes in the display.

rdy display: Calibration completed successfully!

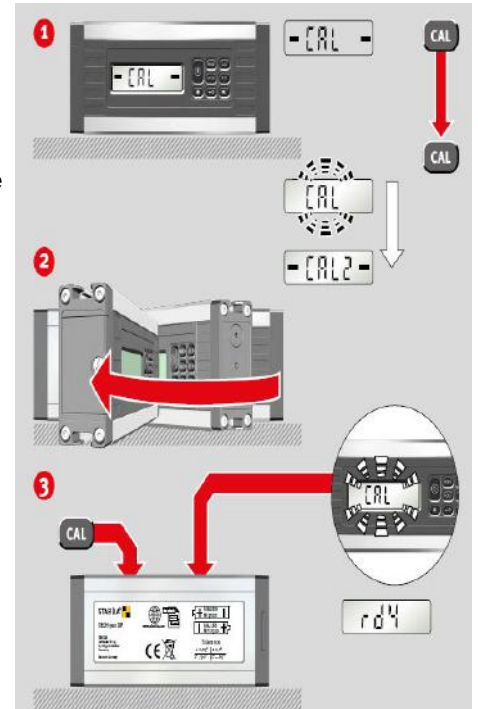

Adjusting the sensor

The sensor must be adjusted if the temperature or Cal. symbols are shown in the display.

A - All 4 planes are adjusted during the sensor adjustment.

B - The sensor can only be adjusted if the two black bars appear on the display (in the range of 0° and 90°).
C - CAL and the planes still to be adjusted flash alternately while the sensor is being adjusted for the respective plane.

D Planes that have not been adjusted flash in the display.

Successfully adjusted planes are permanently indicated in the display.

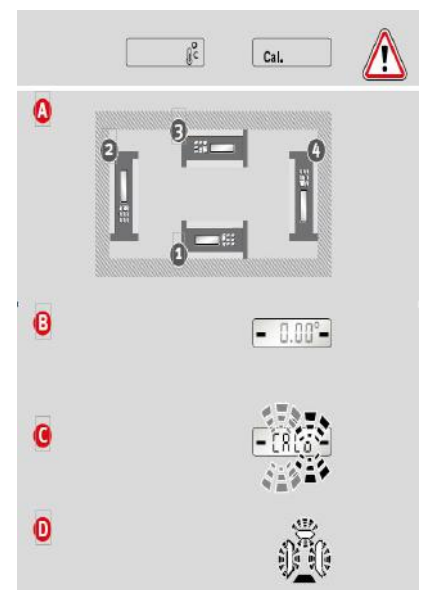

Adjusting the sensor

Step 1: Simultaneously press the "MODE" and "CAL" buttons.



Step 2: Hold the unit in plane 1.

Press the "CAL" button.
If the plane has been adjusted successfully, it is permanently indicated in the display.

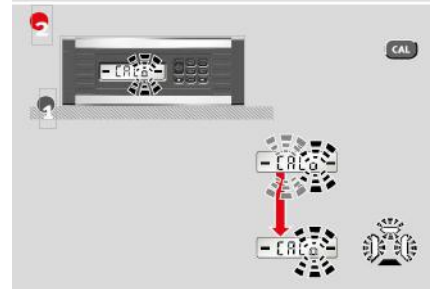

Step 3: Turn the unit by 90° to plane 2.

Press the "CAL" button.
If the plane has been adjusted successfully, it is permanently indicated in the display.

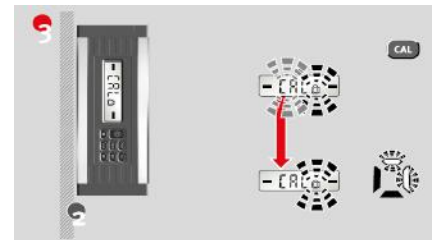

Step 4: Turn the unit by 90° to plane 3.

Press the "CAL" button.
If the plane has been adjusted successfully, it is permanently indicated in the display.

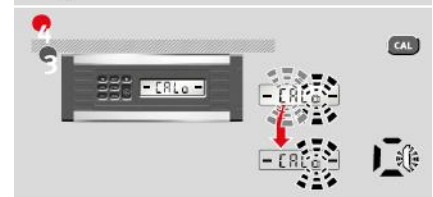

Step 5: Turn the unit by 90° to plane 4.

Press the "CAL" button.
If the last plane has been adjusted successfully, "rdy" is indicated in the display.

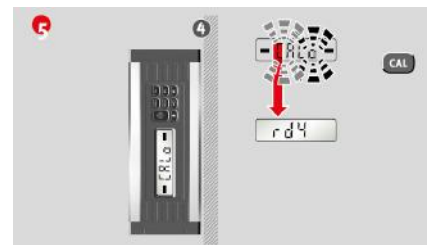

Error messages

Display: Cal. /temperature

The sensor must be adjusted if the temperature or Cal. symbols are indicated in the display.



Display: Err

The unit must not be moved or subjected to vibrations during the calibration/sensor adjustment. This can lead to measurement errors.



Display: - - - -

Unit inclination around longitudinal axis > 10°

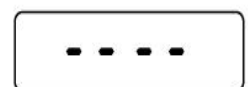



Signalight

+40 254 515 465
office@signalight.com

36 Lunca Street, Petrosani,
Hunedoara County, Romania

www.signalight.com